



BUILDING CODE COMPLIANCE OFFICE (BCCO)
PRODUCT CONTROL DIVISION

MIAMI-DADE COUNTY, FLORIDA
METRO-DADE FLAGLER BUILDING
140 WEST FLAGLER STREET, SUITE 1603
MIAMI, FLORIDA 33130-1563
(305) 375-2901 FAX (305) 375-2908
www.buildingcodeonline.com

NOTICE OF ACCEPTANCE (NOA)

ODL, Inc.
215 East Roosevelt Avenue
Zeeland, MI 49464

SCOPE:

This NOA is being issued under the applicable rules and regulations governing the use of construction materials. The documentation submitted has been reviewed by the BCCO and accepted by the Building Code and Product Review Committee (BCPRC) to be used in Miami Dade County and other areas where allowed by the Authority Having Jurisdiction (AHJ).

This NOA shall not be valid after the expiration date stated below. The BCCO (In Miami Dade County) and/or the AHJ (in areas other than Miami Dade County) reserve the right to have this product or material tested for quality assurance purposes. If this product or material fails to perform in the accepted manner, the manufacturer will incur the expense of such testing and the AHJ may immediately revoke, modify, or suspend the use of such product or material within their jurisdiction. BCPRC reserves the right to revoke this acceptance, if it is determined by BCCO that this product or material fails to meet the requirements of the applicable building code.

This product is approved as described herein, and has been designed to comply with the Florida Building Code, including the High Velocity Hurricane Zone.

**DESCRIPTION: ODL/Western Reflections Series Aluminum Glazed Lite-kit assembly-Impact
(Component Approval)**

APPROVAL DOCUMENT: Drawing No. 18564-150, titled "Hurricane Glazed Door Glass Assembly" sheets 1 through 2 of 2, dated 09/11/02 and last revised on 07-06-2005, prepared by R. W. Building Consultants Inc., signed and sealed by Wendell W. Haney, P.E., bearing the Miami-Dade County Product Control Revision stamp with the Notice of Acceptance number and expiration date by the Miami-Dade County Product Control Division.

MISSILE IMPACT RATING: Large and Small Missile Impact

Limitation: This component can only be installed into impacted glazed doors, having current NOA, or FBC approved.

LABELING: Each unit shall bear a permanent label with the manufacturer's name or logo, city, state and following statement: "Miami-Dade County Product Control Approved", unless otherwise noted herein.

RENEWAL of this NOA shall be considered after a renewal application has been filed and there has been no change in the applicable building code negatively affecting the performance of this product.

TERMINATION of this NOA will occur after the expiration date or if there has been a revision or change in the materials, use, and/or manufacture of the product or process. Misuse of this NOA as an endorsement of any product, for sales, advertising or any other purposes shall automatically terminate this NOA. Failure to comply with any section of this NOA shall be cause for termination and removal of NOA.

ADVERTISEMENT: The NOA number preceded by the words Miami-Dade County, Florida, and followed by the expiration date may be displayed in advertising literature. If any portion of the NOA is displayed, then it shall be done in its entirety.

INSPECTION: A copy of this entire NOA shall be provided to the user by the manufacturer or its distributors and shall be available for inspection at the job site at the request of the Building Official.

This NOA revises NOA # 03-0428.02 consists of this page 1 and evidence pages E-1 as well as approval document mentioned above.

The submitted documentation was reviewed by **Ishaq I. Chanda, P.E.**

NOA No 07-0214.07
Expiration Date: July 28, 2010
Approval Date: March 22, 2007
Page 1



3/1/07

NOTICE OF ACCEPTANCE: EVIDENCE SUBMITTED

- A. DRAWINGS** (transferred from file # 03-0428.02)
1. Manufacturer's die drawings and sections.
 2. Drawing No. **18564-150**, titled "Hurricane Glazed Door Glass Assembly" sheets 1 through 2 of 2, dated 09/11/02 and last revised on 07-06-2005, prepared by R. W. Building Consultants Inc., signed and sealed by Wendell W. Haney, P.E.
- B. TESTS** (transferred from file # 03-0428.02)
1. Test reports on 1) Air Infiltration Test, per FBC, TAS 202-94
2) Uniform Static Air Pressure Test, Loading per FBC, TAS 202-94
3) Water Resistance Test, per FBC, TAS 202-94
4) Large Missile Impact Test per FBC, TAS 201-94
5) Cyclic Wind Pressure Loading per FBC, TAS 203-94
6) Forced Entry Test, per FBC 2411.3.2.1 (b) and TAS 202-94
Along with installation diagrams of aluminum glazed lite-kit doors, prepared by Certified Test Laboratories Inc., Test Report No. **CTLA-1042 W & CTLA-1042W-1**, both dated March 21, 2003, signed and sealed by Ramesh Patel, P.E.
- C. CALCULATIONS:** (transferred from file # 03-0428.02)
1. Anchor verification calculation dated 04/16/2003, prepared by R. W. Building Consultants, Inc, signed and sealed by Lyndon F. Schmidt, P.E.
 2. Glazing complies w/ASTME-1300-98
- D. QUALITY ASSURANCE**
1. Miami Dade Building Code Compliance Office (BCCO)
- E. MATERIAL CERTIFICATIONS** (transferred from file # 03-0428.02)
1. Notice of Acceptance **05-0921.09** issued to ODL for "HP Polypropylene " lite frame material, expiring Jan 17, 2011.
 2. Notice of Acceptance No. **03-0421.01** issued to Solutia, Inc. for "Saflex HP", expiring on 4/18/2008.
 3. Tensile test per ASTM E8/A-370, report No. 1042W, dated 27th March 2003, issued by Certified Testing laboratories.
 4. Tensile test per ASTM E8/A-370, report No. 1042W-1, dated 27th March 2003, issued by Certified Testing laboratories.
- F. STATEMENTS** (transferred from file # 03-0428.02)
1. Statement letter of conformance and no financial interest dated 04/17/2003, signed and sealed by Lyndon F. Schmidt, P.E.
 2. Statement letter of conformance and no financial interest dated 07/06/2005, signed and sealed by Wendell W. Haney, P.E
 3. Statement letter of Lab compliance, as part of above test reports.
- G. OTHER**
1. This NOA revises NOA # **03-0428.02**, expiring **July 28, 2010**.
 2. NOA # **05-0921.09** issued to ODL for "HP Polypropylene " lite frame, exp Jan 17, 2011.
 3. Test proposal # **02-0541**, dated October 10, 2002 approved by BCCO.

Ishaq I. Chanda

Ishaq I. Chanda, P.E.

Product Control Examiner

NOA No 07-0214.07

Expiration Date: July 28, 2010

Approval Date: March 22, 2007

ODL 215 EAST ROOSEVELT
ZEELAND, MI 49464
PH: 616.772.9111 FAX: 616.772.3840
ODL/WESTERN REFLECTIONS
HURRICANE GLAZED IMPACTED LIGHT KIT ASSEMBLY
FOR GLAZING UP TO A 3'0" x 8'0" PANEL

GENERAL NOTES

1. THIS PRODUCT IS DESIGNED TO MEET THE FLORIDA BUILDING CODE FOR HIGH VELOCITY ZONE.
2. PRODUCTS LISTED IN THIS NOA (NOTICE OF ACCEPTANCE) SHALL BE USED IN CONJUNCTION WITH CURRENT GLAZED IMPACTED NOA'S UTILIZING SIMILAR COMPONENTS AND WILL BE LIMITED BY THE LESSER DESIGN PRESSURE PRODUCTS CAN BE USED WITH STEEL, WOOD AND STEEL EDGES, SIDE HINGED SWING/DOORS OR FIXED DOORS SEE CORRESPONDING ELEVATIONS THIS SHEET.
3. DESIGNED PRESSURE RATING SEE TABLE PAGE 1.
4. PRODUCTS LISTED IN THIS NOA MEET REQUIREMENTS FOR HIGH VELOCITY HURRICANE WIND BORNE DEBRIS ZONES AS PRESCRIBED IN SECTION 1626 OF THE FLORIDA BUILDING CODE, BUT ARE LIMITED BY THE NOA'S THAT THEY ARE USED IN CONJUNCTION WITH.
5. WHEN THIS PRODUCT IS USED IN AREAS REQUIRING WIND BORNE DEBRIS PROTECTION FLORIDA BUILDING CODE APPROVED IMPACT RESISTANT SHUTTERS ARE NOT REQUIRED PROVIDED THE LITE INSERTS ARE INSTALLED IN A DADE COUNTY APPROVED LARGE MISSILE IMPACT RESISTANT DOOR PANEL.

LIMITATION:

1. THE IMPACTED LIGHT KIT ASSEMBLY, AS A COMPONENT, IS TO BE USED AS A SUBSTITUTE TO A SIMILAR GLAZED IMPACTED DOOR LIGHT ASSEMBLY, IN AN ALREADY APPROVED IMPACTED SINGLE GLAZED DOOR SYSTEM, OF THE SAME OR SUPERIOR CONSTRUCTION, HAVING CURRENT NOA (NOTICE OF ACCEPTANCE).
2. THE LOWER DESIGN PRESSURE OF THIS COMPONENT OR THE APPROVED SYSTEM NOA WILL CONTROL.
3. THIS PRODUCT CANNOT BE APPROVED WITH OPAQUE DOOR SYSTEM NOA.

SPECIFICATION FOR LIGHT FRAME MATERIAL AND DOOR PANELS:

1. ODL/WESTERN REFLECTIONS ALUMINUM LITE FRAME KIT, APPROVED UNDER THIS NOA.
2. SINGLE GLAZED IMPACTED DOOR PANELS SHOWN ARE UNDER SEPARATE DOOR SYSTEM NOA(S). THE DOOR PANELS MUST MEET FOLLOWING MINIMUM REQUIREMENTS TO BE QUALIFIED WITH THIS COMPONENT:
 1. SINGLE GLAZED STEEL DOOR (STEEL EDGE), SWINGING TYPE (1-3/4" MIN THICK PANEL):
 1. STEEL FACE SHEET: 24 GAUGE (.022" MIN.) OR BETTER WITH Fy MIN=43,270 psi.
 2. STILE: .040" THK. ROLL FORMED STEEL, REINFORCEMENT WITH 1.69" X .5" U-CHANNEL.
 3. RAILS: .040" THK. ROLL FORMED STEEL, REINFORCEMENT WITH 1.69" X .5" U-CHANNELS (TOP/BOTTOM).
 4. FOAM CORE: APPROVED 2-2.5/FT³ DENSITY POLYURETHANE OR 2.0#/FT³ DENSITY POLYSTYRENE, COMPLYING TO FBC.
 5. THIS PRODUCT SHALL BE INSTALLED IN A MAXIMUM PANEL SIZE OF 36" WIDE & 96" HIGH (SEE DESIGN PRESSURE TABLE).
3. SINGLE GLAZED FIXED DOOR. (WOOD EDGE/STEEL EDGE). 1-3/4" MIN THK. PANEL.
 1. STEEL FACE SHEET: 24 GAUGE (.022") MIN. OR BETTER WITH Fy MIN.=52,190 psi.
 2. STILE: PINE 1.531" X 1.183" (WOOD EDGE).
 3. RAILS: WOOD COMPOSITE 1.531" X 94" (WOOD EDGE)
 4. STILE (STEEL EDGE): .040" THK. ROLL FORM STEEL, REINFORCED WITH 1.69" X .5" U-CHANNEL.
 5. RAILS (STEEL EDGE): .040" THK. ROLL FORM STEEL, REINFORCED WITH 1.69" X .5" U-CHANNELS (TOP/BOTTOM).
 6. FOAM CORE: APPROVED 2-2.5 #/FT³ DENSITY POLYURETHANE OR 2.0 #/FT³ DENSITY POLYSTYRENE COMPLYING TO FBC.
 7. THIS PRODUCT SHALL BE INSTALLED IN A MAXIMUM PANEL SIZE OF 36" WIDE & 96" HIGH (SEE DESIGN PRESSURE TABLE).

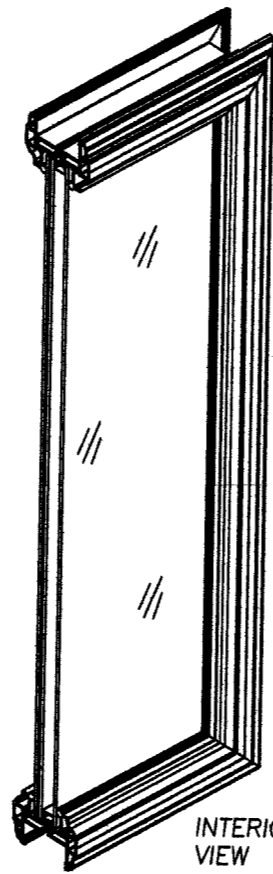

ALUMINUM LIGHT KIT DETAIL (TYP)

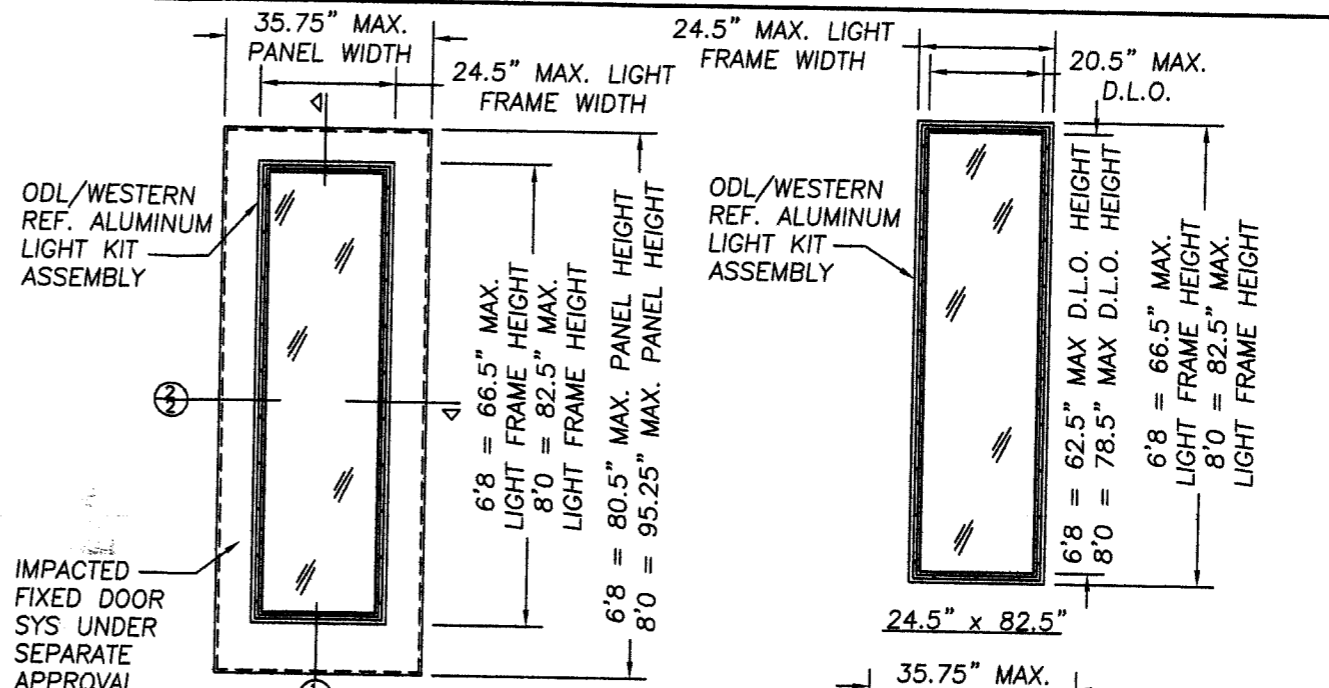

SINGLE FIXED STEEL PANEL (WOOD EDGE OR STEEL EDGE)

LIGHT KIT DESIGN PRESSURE, W/STEEL PANEL (WOOD EDGE OR STEEL EDGE)	
8'-0"	± 65 PSF
6'-8"	± 65 PSF

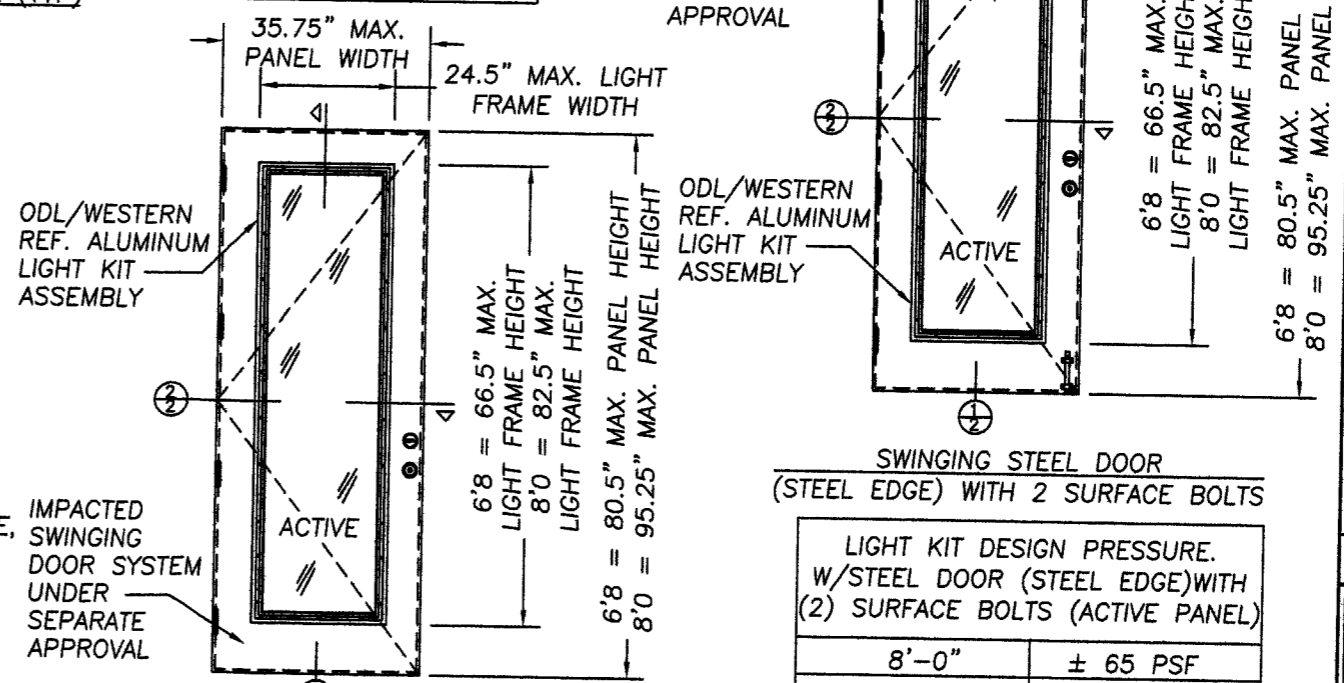

SWINGING STEEL DOOR (STEEL EDGE)

LIGHT KIT DESIGN PRESSURE, W/STEEL DOOR (STEEL EDGE) WITHOUT SURFACE BOLTS	
8'-0"	± 40 PSF
6'-8"	± 45 PSF

PRODUCT REVISED
as complying with the Florida Building Code
Acceptance No. 07-0214.07
Expiration Date July 28, 2010
By Ishag J. Chande
Miami Dade Product Control Division

Approved as complying with the Florida Building Code
Date July 28, 2005
NOA# 03-0428.02
Miami Dade Product Control Division
By Ishag J. Chande

Documents Prepared By:
RW BUILDING CONSULTANTS, INC.
P.O. Box 230 Valrico FL 33595
Phone No.: 813.659.9197
Florida Board of Professional Engineers
Certificate Of Authorization No. 9813
Wendell W. Honeoy 7/6/05
Wendell W. Honeoy, P.E. No. 54158

PRODUCT: HURRICANE GLAZED DOOR GLASS ASSEMBLY
PART OR ASSEMBLY: HURRICANE GLAZING
GENERAL NOTES & ELEVATIONS

NO.	DATE	REVISIONS
5	06/29/05	PER DADE LETTER
4	06/17/05	PER DADE LETTER
3	04/05/05	PER CTL ADDENDUM LTR
2	7/03/03	ADD ANCHORING DETAILS
1	2/27/03	RELEASE FOR PRODUCTION

RW BUILDING CONSULTANTS, INC.
813.659.9197

DATE: 9/11/02
SCALE: N.T.S.
DWG. BY: B.H.
CHK. BY: R.W.
DRAWING NO.: 18564-150
SHEET 1 OF 2

I:\Rwbsrv\wbc\Proj 000-250\p1 81\1Dade drawings\REV 5118564-1R.dwg

IRWbcsrv\wbc\Proj 000-250\p181\Date drawings\REV 5\18564-2R.dwg

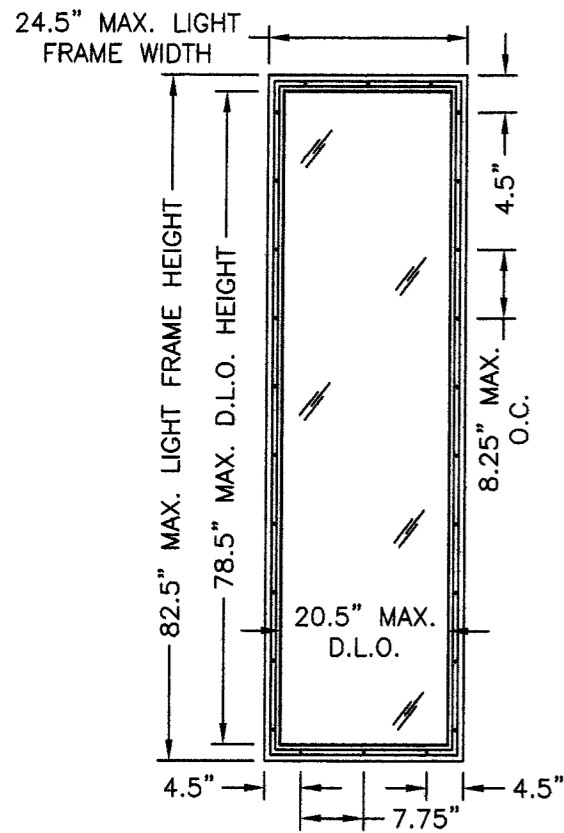

ODL/WESTERN REF. ALUMINUM LIGHT KIT ASSEMBLY
8'0" UNITS

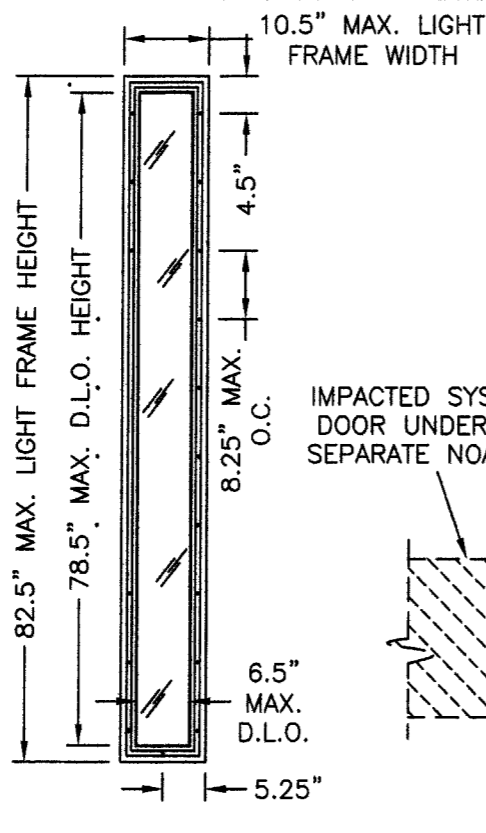

ODL/WESTERN REF. ALUMINUM LIGHT KIT ASSEMBLY
6'8" UNITS

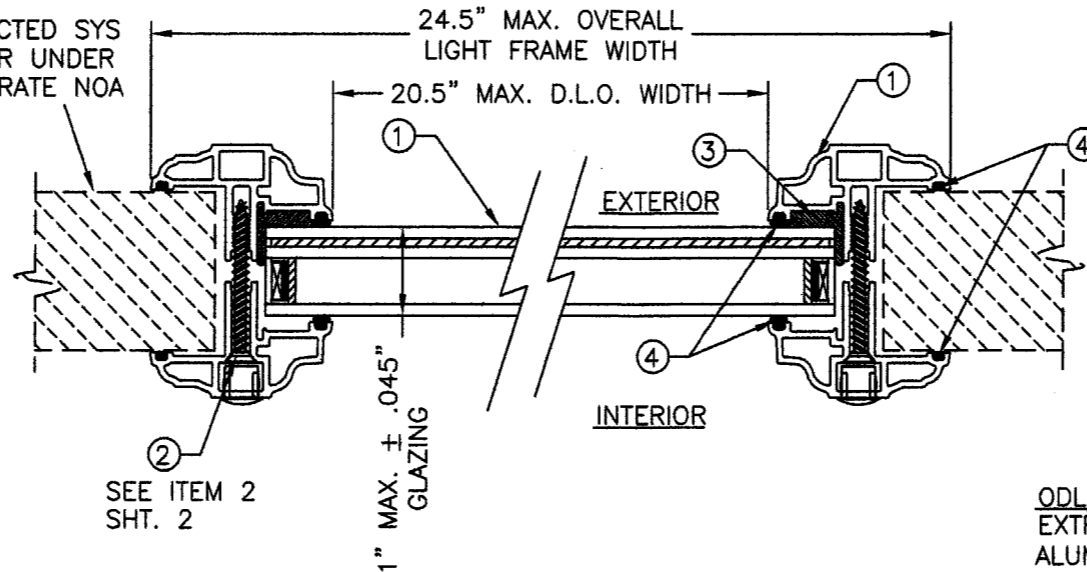

2 HORIZONTAL CROSS SECTION

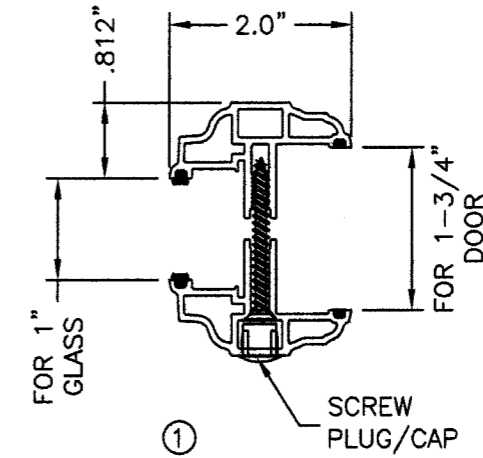

ODL/WESTERN REFLECTION HURRICANE LIGHT FRAME KIT
EXTRUDED ALUMINUM 0.070" MIN. WALL THK.
ALUMINUM ALLOY - 6063-T5

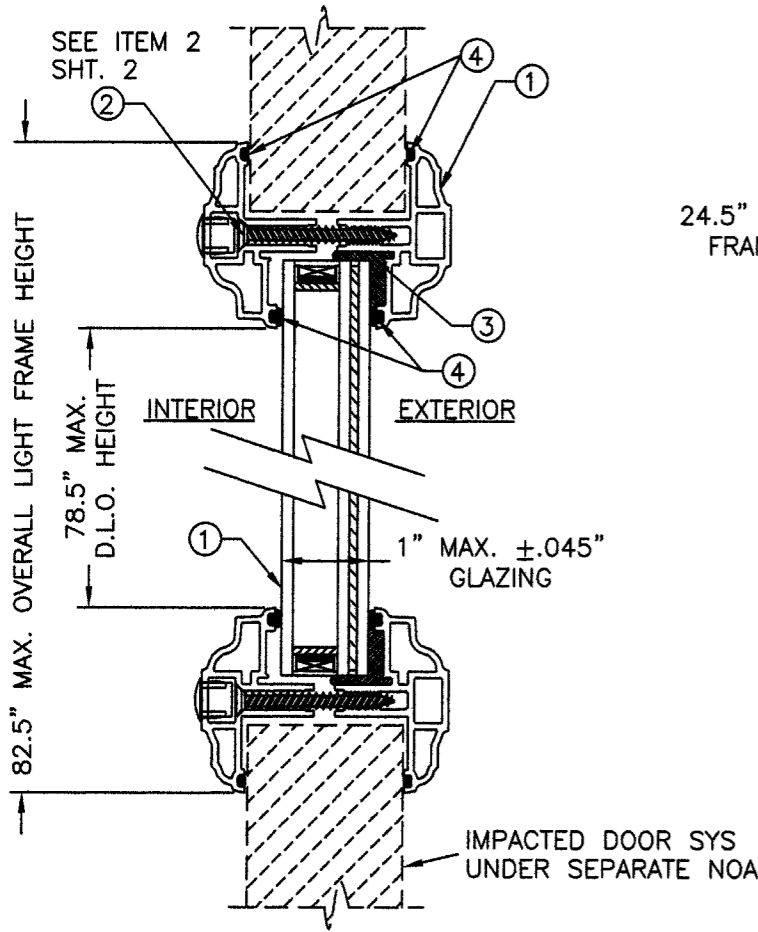

1 VERTICAL CROSS SECTION

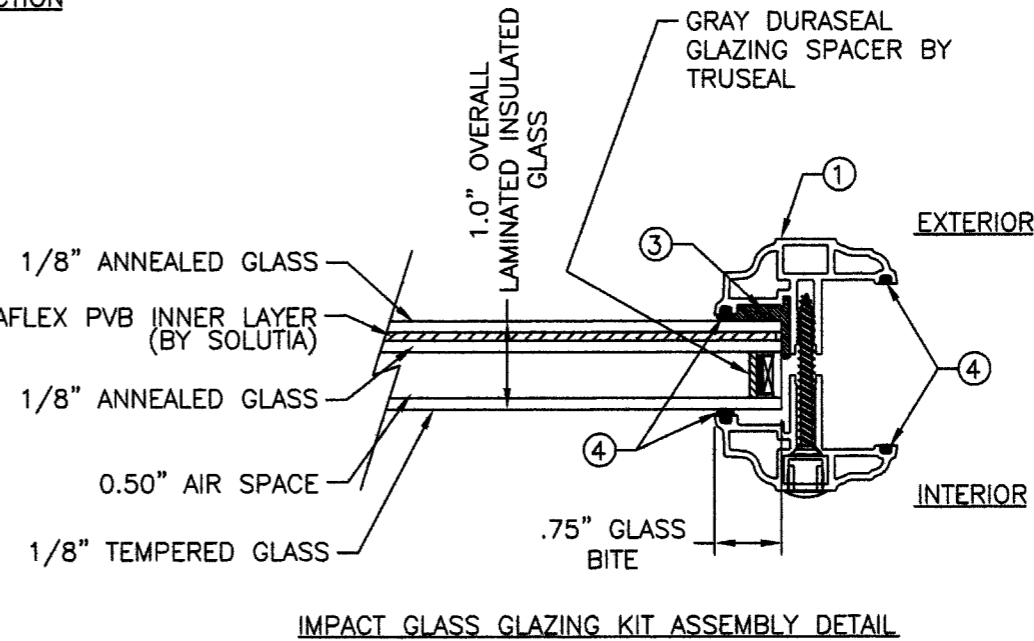
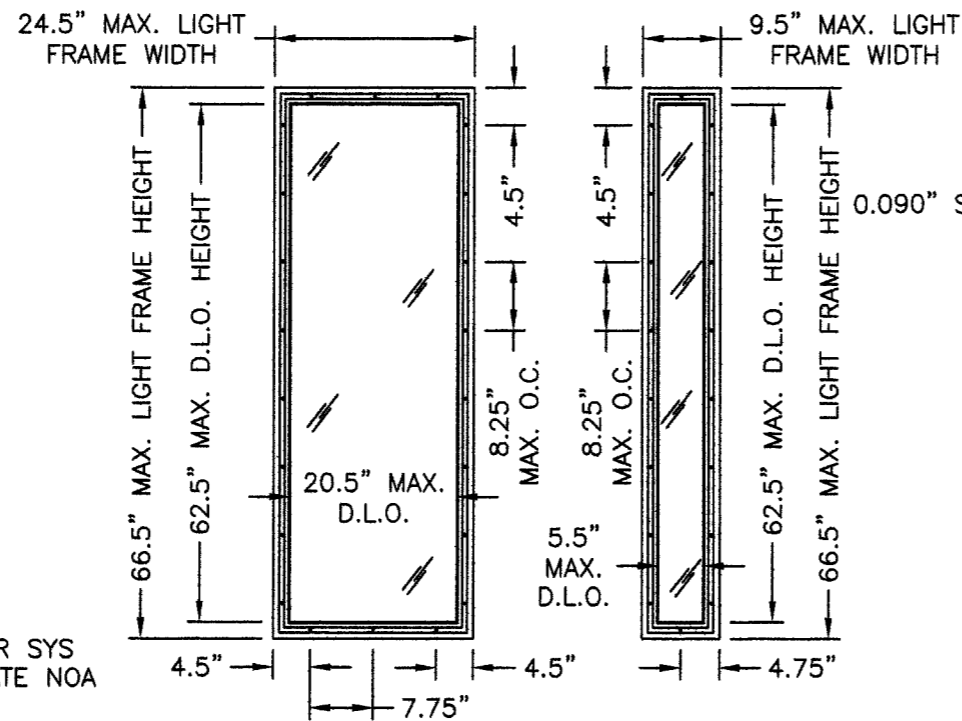

IMPACT GLASS GLAZING KIT ASSEMBLY DETAIL

ITEM	DESCRIPTION	MATERIAL
1	ODL/WESTERN REFLECTION ALUMINUM LIGHT KIT ASSEMBLY CONSIST OF EXTRUDED ALUMINUM FRAME WITH 1" OVERALL LAMINATED INSULATED GLASS (1/8" ANN + .090" SAFLEX PVB + 1/8" ANN + 0.50 AIR SPACE + 1/8" TEMPERED GLASS)	GLASS/ALUM
2	#10 x 1 3/4" TYPE AB FLAT HEAD SCREW (LIGHT FRAME SCREW)	STEEL
3	STRUCTURAL SILICONE DOW CORNING #995	SILICONE
4	GLAZING COMPOUND REDI-SEAL BY ODL, POLYMERIC FOAM	POLYMERIC FOAM

PRODUCT REVISED
as complying with the Florida Building Code
Acceptance No. 07-0214.07
Expiration Date July 28, 2010
By Ismael Chanda
Miami Dade Product Control Division

Approved as complying with the Florida Building Code
Date July 28, 2005
NOA# 03-0428-02
Miami Dade Product Control Division
By Ismael Chanda

Documents Prepared By:
RW BUILDING CONSULTANTS, INC.
P.O. Box 230 Vero Beach, FL 33595
Phone No.: 813.659.9197
Florida Board of Professional Engineers
Certificate of Authorization No. 9813
Wendell W. Flaherty
Wendell W. Flaherty, P.E. No. 54158

PRODUCT: HURRICANE GLAZED DOOR GLASS ASSEMBLY
PART OR ASSEMBLY: HURRICANE GLAZING CROSS SECTIONS

NO.	DATE	REVISIONS
5	06/29/05	AM PER DATE LETTER
4	06/17/05	AM PER DATE LETTER
3	04/05/05	WH PER C.T.L. ADDENDUM LTR
2	7/03/03	RL ADD ANCHORING DETAILS
1	2/27/03	RL RELEASE FOR PRODUCTION
		BY

RW BUILDING CONSULTANTS, INC.
813.659.9197

DATE: 9/11/02
SCALE: N.T.S.
DWG. BY: B.H.
CHK. BY: R.W.
DRAWING NO.: 18564-150
SHEET 2 OF 2